



POWER PRODUCTS

TWO CYCLE ADVANTAGE

# ELECTRO-MOTIVE

*The EMD 710 series engine  
available in 8, 12, 16 and 20 cylinder  
configurations with continuous power  
ratings from 2000 to 5000 hp*

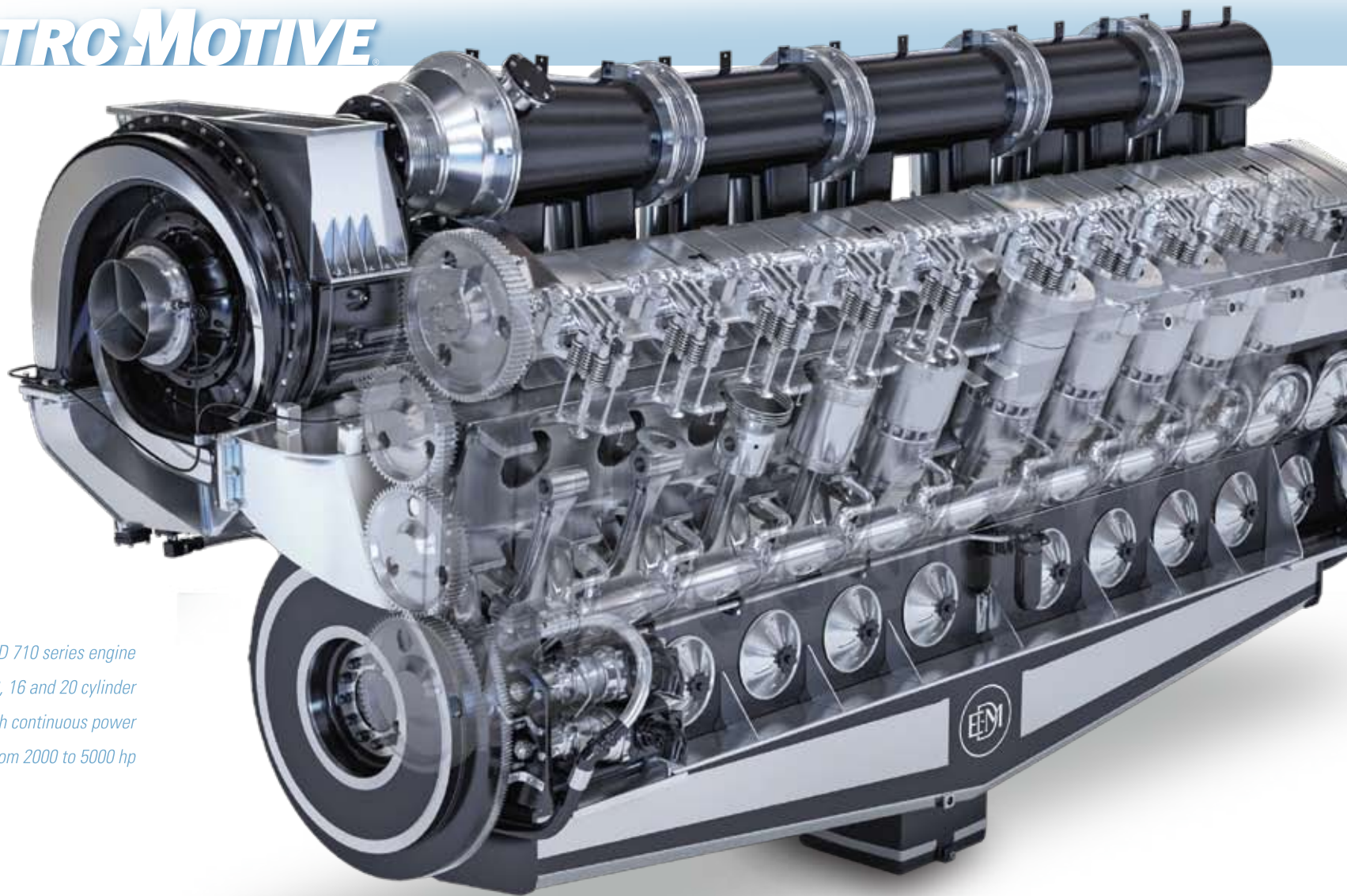



POWER PRODUCTS

### **The 710 Series Two Cycle Advantage**

Electro-Motive Diesel, Inc (EMD), headquartered in LaGrange, Illinois, USA is the world leader in manufacturing two cycle, medium speed engines for marine, drilling, power generation, and locomotive markets. The EMD 710 series engine is available in 8, 12, 16, and 20 cylinder configurations with continuous power ratings from 2000 to 5000 horsepower.

EMD's history with the marine industry began in 1930, when the US Navy approached EMD to develop a lighter, more powerful engine for a new fleet of diesel electric submarines. This engine, the Winton 201, was the first two-stroke diesel engine ever used in a marine application.

By the late 1930's, the EMD 567 Series engine was introduced and eventually replaced the Winton 201. In 1942, the US Navy

again turned to EMD — this time to power the LSTs (Tank Landing Ships) with the 567 Engine. By 1945, EMD had delivered over 1000 engines to power these famous boats.

Today, the EMD 710 Series continues to build on the time tested features of the Winton 201 and 567 Series. Customers, world-wide, continue to choose the EMD 710 for its significant advantages in power, durability,

and responsiveness that is unmatched in the industry. To date, over 70,000 EMD medium speed diesel engines have been delivered worldwide.

The simple and robust design of EMD's two cycle engine has stood the test of time by adapting to new demands and requirements. EMD continues to build on this legacy, committed to increased performance, durability, reliability, and maintainability.

## Design, Manufacturing and Testing

Building on the simple and efficient design of the two cycle engine, EMD continues to respond and adapt to the changing requirements of our customers. Innovations and advancements in reliability, durability, maintainability, and emissions compliance set the benchmark for others to follow.

EMD innovation led to the development of the first welded 45° vee crankcase. This time-tested advancement has provided the

platform for increased horsepower, improved durability, and offers major advantages in installation and repairs. Complicated and long lead-time castings are not an issue as the EMD crankcase is fabricated at our LaGrange, Illinois production facility.

The lower firing pressures of the two cycle engine allow EMD to use a simple cast iron one piece floating piston. The piston is tin plated – the best break-in and

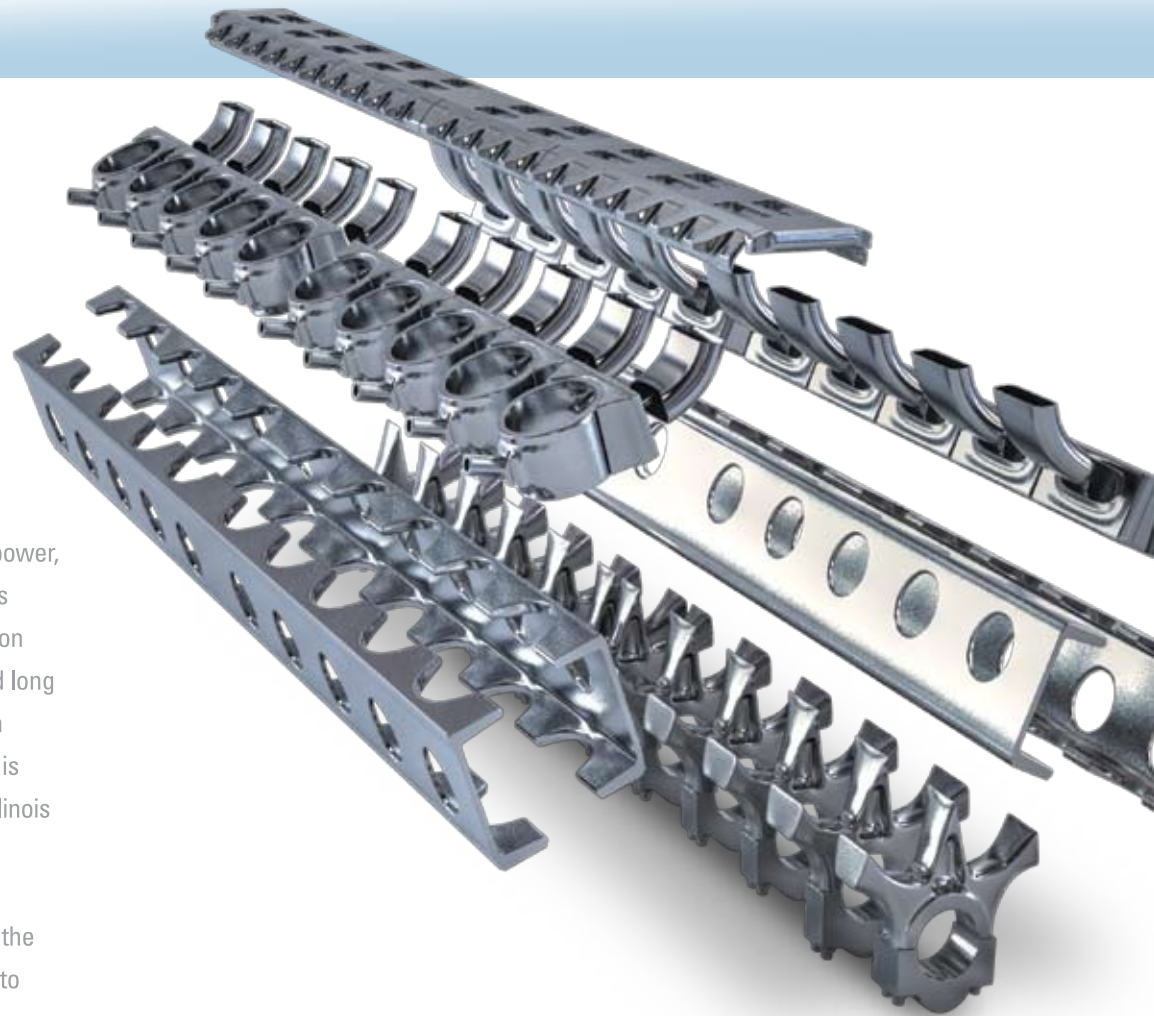



POWER PRODUCTS



operational coating available – providing unsurpassed protection against scuffing. EMD pistons also have hardened top ring grooves to insure longer life.

EMD pioneered the use of laser hardening cylinder liners. With precision honing and a 100% hardened upper bore, EMD manufactures the straightest most durable liner available for use in marine and power generation applications.

No system is more robust than the EMD rocking style system pin and carrier. Specifically designed for high horse power engines, the system provides the ultimate in durability, and minimal downtime, for your application.

EMD works closely with regional suppliers of critical components on a just in time basis. This allows us to shorten lead times and manage costs to provide competitive products in a global market.



# ELECTRO-MOTIVE<sup>®</sup>

## Performance and Simplicity

The EMD two cycle 710 engine is the most responsive in the world. With generator sets, testing proves our 5000 HP 20 cylinder engine is able to accept full load in one step and recover speed in 2 seconds. Similar testing in marine applications has demonstrated acceleration from idle to full load in less than 11 seconds.

By firing each cylinder once per revolution and benefiting from plentiful combustion air through

our unique clutched turbocharger design, the 710 engine is unique in its ability to smoothly accept load at any engine speed, and at a rate no other medium speed engine in the world can match.

EMD's rapid response allows for safer operation, less spinning horsepower, fuel savings, and reduced component wear. All the more reason why, today, naval architects design and build around EMD engines.





POWER PRODUCTS

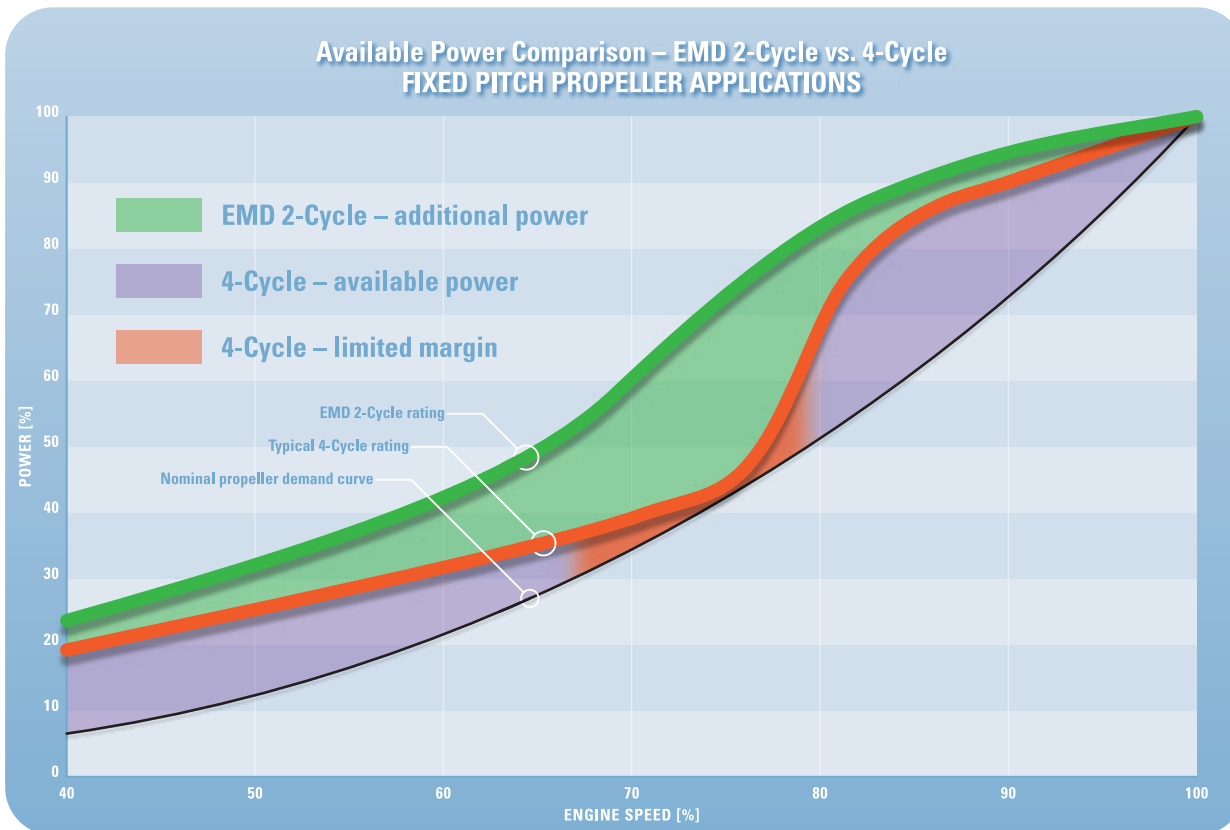

*The EMD 2-cycle engine provides a large margin of available power above the demand curve to provide superior acceleration and responsiveness. By comparison, in fixed pitch propeller applications, the available power of a typical 4-cycle engine narrowly meets the propeller demand curve, especially in the middle to upper engine speed range. Load variations, due to changes in operating conditions, risk increasing the power demand into regions that can overload 4-cycle engines.*

*The additional power capacity of the EMD 2-cycle engine provides better responsiveness and allows operation at any point up to the continuous rating, enabling it to accept virtually any pitch at any rate without overload.*

*4-cycle engine manufacturers limit available engine power to levels significantly below their engine's continuous rating in order to protect against engine overload.*

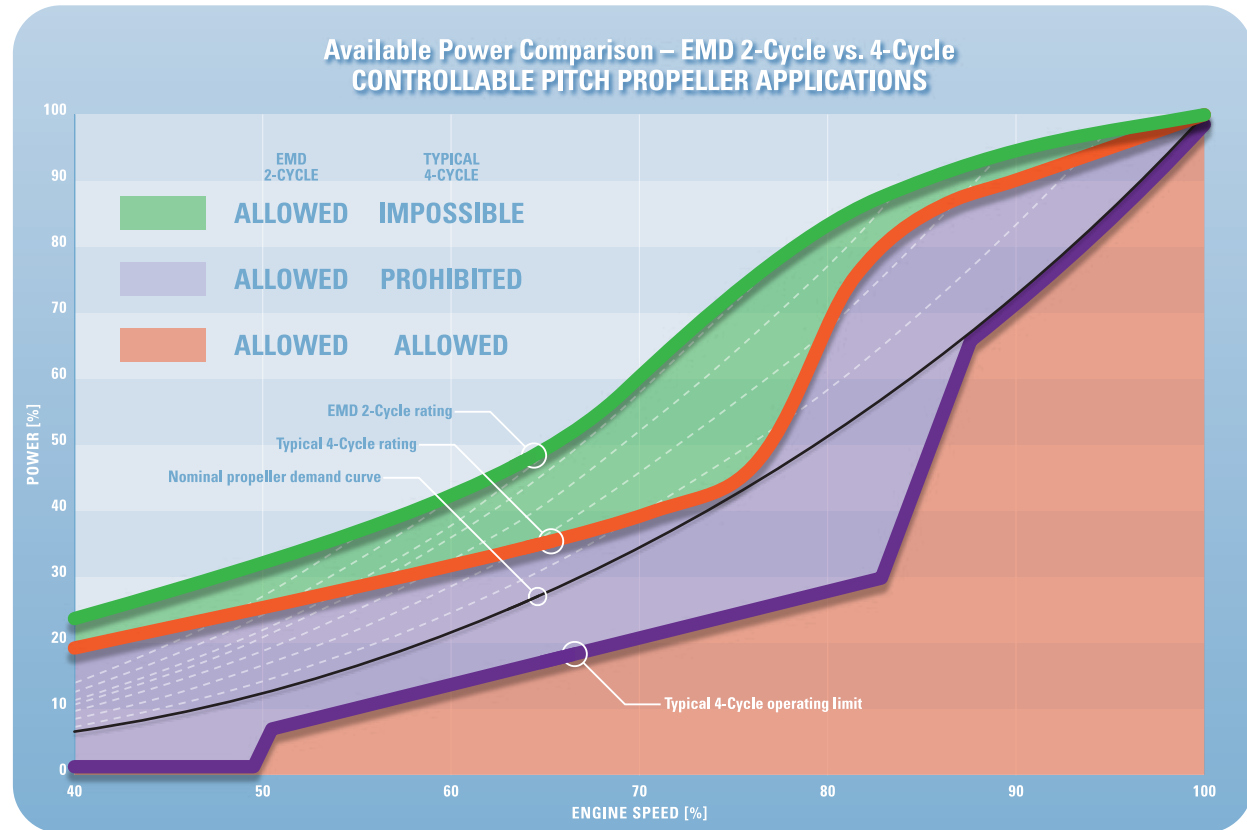





POWER PRODUCTS

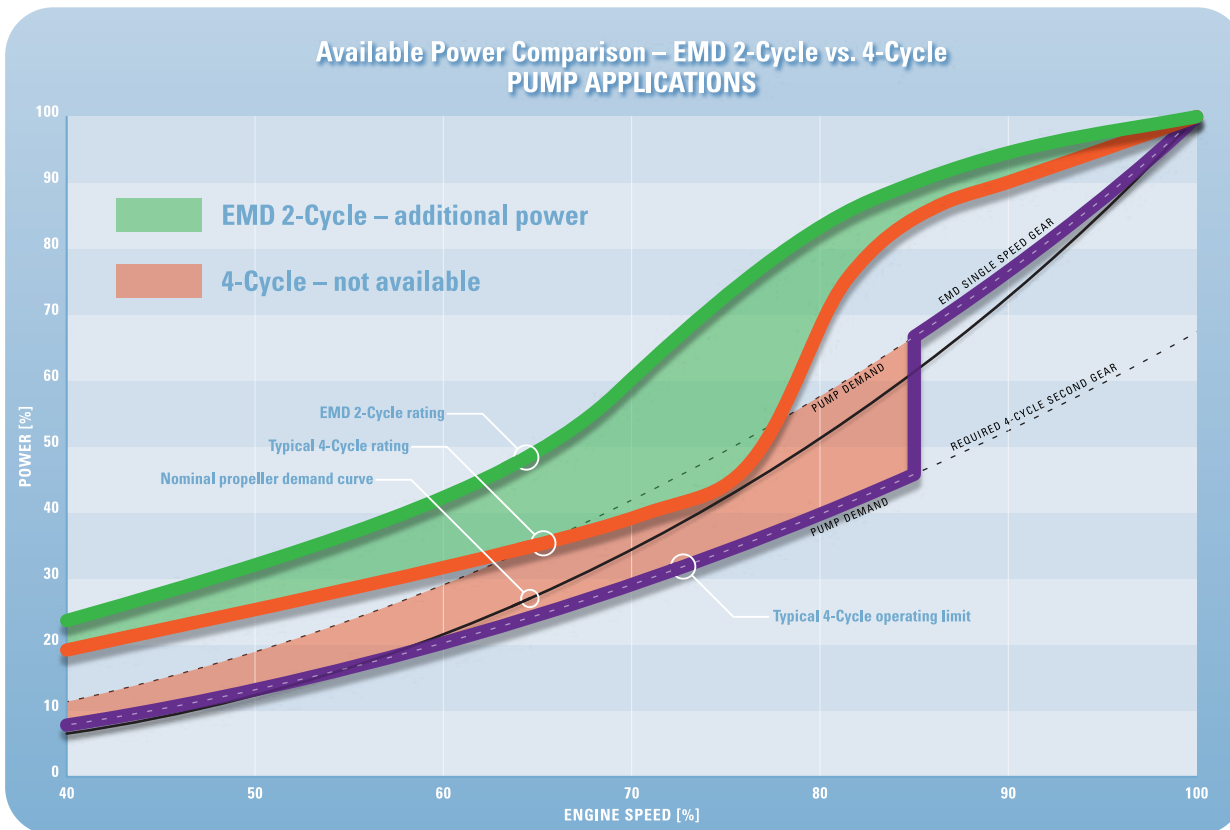

*With abundant available power above the pump demand curve, the EMD 2-cycle engine is more responsive and productive with a lower cost single gear driveline. Typically, single gear driveline causes pump demand curves to exceed a 4-cycle engine's power rating at engine speeds lower than 85% of rated.*

*A 4-cycle engine is restricted to operate in a very narrow range compromising productivity and fuel consumption, requiring a second gear in the driveline.*

## Current and Future Emissions

All 710 engines are certified for US EPA Tier 2, as well as IMO Annex VI Tier 1 and we already surpass IMO Tier 2 [effective 2011]. EMD is actively working on US EPA Tier 4 and IMO Tier 3 standards which become effective in 2014. The EMD two cycle engine has responded well to the technologies required to meet these standards and we expect to have more efficient and cost effective solutions due to inherent advantages over four cycle engines.

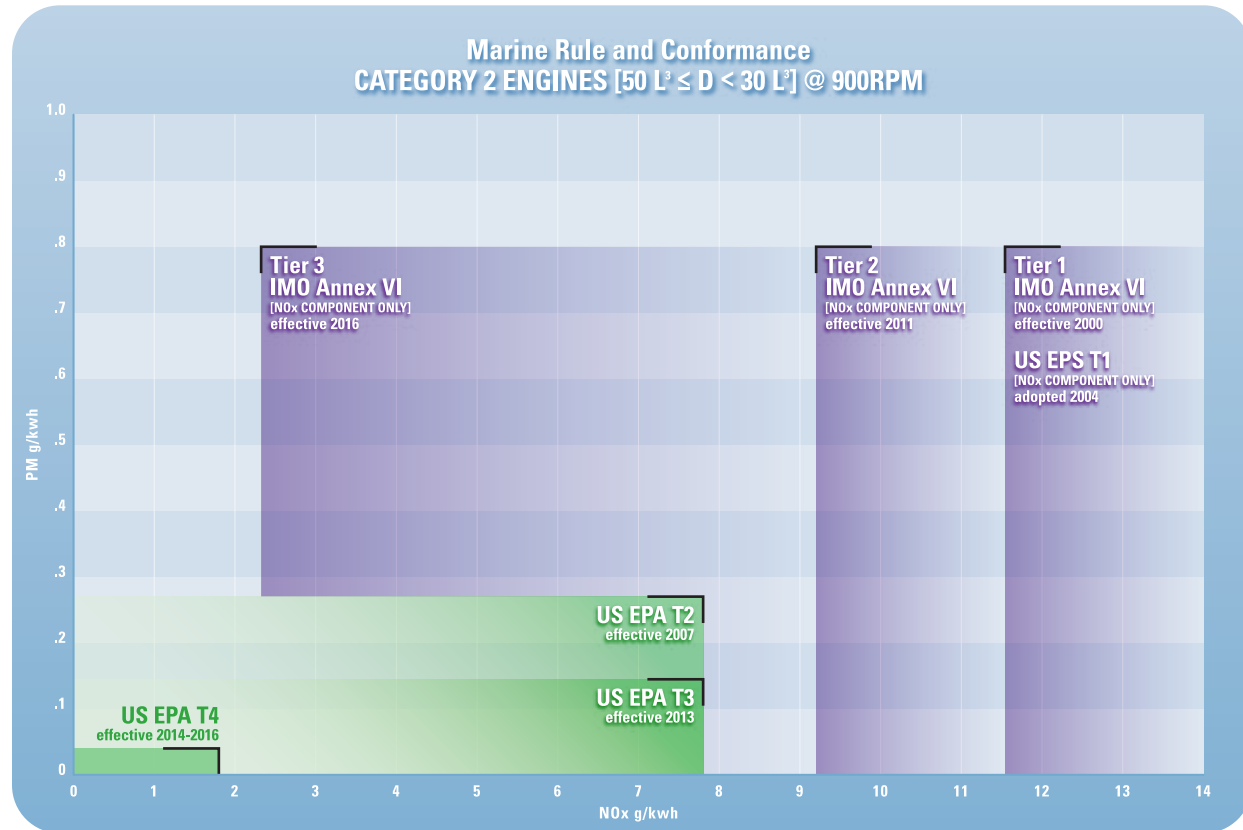



POWER PRODUCTS

CCS Type Approval Added March, 2010



## EMD 710 Engine Ratings and Configurations

ENGINE	900 RPM		800 RPM		720 / 750 RPM	
	BHP	KW	BHP	KW	BHP	KW
<b>8-710G</b>	2000	1491	1760	1312	1675	1249
<b>12-710G</b>	3000	2237	2650	1976	2495	1861
<b>16-710G</b>	4000	2983	3525	2629	3325	2479
<b>20-710G</b>	5000	3729	4400	3281	4155	3098

### ENGINES AVAILABLE IN THREE CONFIGURATIONS

- G4C-T2** Stationary Power Applications
- G7C-T2** Marine Applications
- G9C-T2** Drilling Applications meeting MODU inclination requirements

All EMD engines are rated at full continuous kW ratings with a 10% overload for 2 out of every 24 hours.  
All ratings include engine mounted oil, water and fuel pumps.

EMD ENGINES ARE CERTIFIED BY



The reliability, durability and emissions performance of all EMD engines is maximized with the use of #2 diesel fuel. EMD publishes specifications for this fuel along with additional recommendations for sulfur, cleanliness and other properties. EMD engines will meet or exceed regular maintenance intervals and life under typical operating conditions if #2 diesel fuel is used. However, EMD engines have been successfully

operated with lower cost Marine Distillate fuels such as DMX, DMA, and DMB and various blends of biodiesel and jet fuels. These fuels may require additional fuel system support equipment to meet minimum specifications as well as the use of chrome cylinder liners.

Contact your authorized EMD distributor for details.

Marine Engine Model	A Height - Over Basic Exhaust Outlet Adapter		B Height - Over Basic Exhaust Outlet		C Depth - Mounting Pads To Pan Bottom		D Height - Over Exhaust Manifold Heat Shield		E Width - Over Turbo Aftercooler Pipes	
	US Std	Metric	US Std	Metric	US Std	Metric	US Std	Metric	US Std	Metric
ME 8G7C	10' 7-13/16"	3.246m	8' 5-5/16"	2.573m	18-7/8"	0.479m	9' 1-7/8"	2.790m	69-1/2"	1.765m
ME 12G7C	11' 2-1/4"	3.41m	9' 0"	2.764m	24-7/8"	0.632m	9' 8-1/16"	2.948m	68-1/2"	1.740m
ME 16G7C	11' 2-1/4"	3.41m	9' 0"	2.764m	24-7/8"	0.632m	9' 8-1/16"	2.948m	68-1/2"	1.740m
ME 20G7C	11' 11-3/8"	3.642m	9' 8-13/16"	2.966m	32-7/8"	0.835m	10'4"	3.150m	69-1/2"	1.765m

Marine Engine Model	F Length - Air Filter Overhang		G Length - Engine To Cooling Water Pipe Flange		H Length - Engine Crankcase		I Length - Overall Engine/ Rack/ Air Filter		J Length - Over Turbo Aftercooler Ducts	
	US Std	Metric	US Std	Metric	US Std	Metric	US Std	Metric	US Std	Metric
ME 8G7C	7' 0"	2.134m	8' 0-1/8"	2.441m	6' 1-3/8"	1.864m	20' 4-5/32"	6.202m	36.59"	0.929m
ME 12G7C	7' 4-3/16"	2.240m	8' 0-1/8"	2.441m	8' 11-5/8"	2.734m	23' 6-19/32"	7.178m	41.34"	1.050m
ME 16G7C	7' 3-3/4"	2.240m	8' 0-1/8"	2.441m	12' 2-1/4"	3.715m	26' 9-11/16"	8.171m	41.34"	1.050m
ME 20G7C	7' 4-3/16"	2.240m	8' 0-1/8"	2.441m	14' 11-1/2"	4.559m	29' 6-15/16"	9.015m	41.34"	1.050m

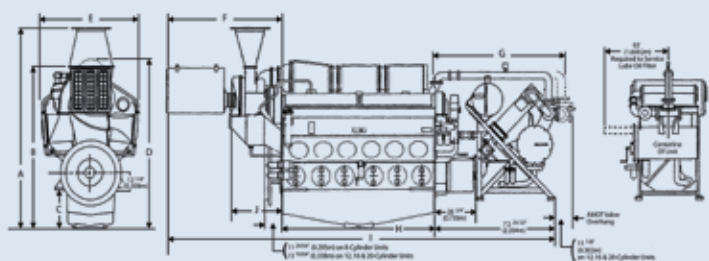
Marine Engine Model	Weights				
	Engine - Dry		Accessory Rack		
	US Std	Metric	US Std	Metric	
ME 8G7C	26,000 lbs.	11,800 kg.	3,700 lbs.	1,680 kg.	
ME 12G7C	33,000 lbs.	15,000 kg.	3,700 lbs.	1,680 kg.	
ME 16G7C	40,500 lbs.	18,365 kg.	3,700 lbs.	1,680 kg.	
ME 20G7C	46,700 lbs.	21,180 kg.	3,800 lbs.	1,725 kg.	

From a distributor network that works closely with EMD performance and application engineers to design, install and service systems world-wide... to a service center organization that provides OEM parts from multiple warehouse locations and expertly trained mechanics around the world... to classroom training at our state of the art training facility... you can depend on EMD to provide what our customers want and the competition can't.

**ELECTRO-MOTIVE**

9301 West 55th St. » LaGrange, IL 60525 » 708.387.6000 » [www.EMDiesels.com](http://www.EMDiesels.com)